

# ELEMENTY ZŁĄCZNE BSP

BSP XGE BSPT  
BSP XGE NPT

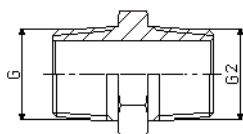

Ciśnienie BAR	Gwint [G]	Gwint [G2]	Oznaczenie <b>BSP XGE BSPT</b>	Oznaczenie <b>BSP XGE NPT</b>
350	1/8"	1/8"	BSP XGE 1/8x1/8 BSPT	BSP XGE 1/8x1/8 NPT
	1/8"	1/4"	BSP XGE 1/8x1/4 BSPT	BSP XGE 1/8x1/4 NPT
	1/4"	1/4"	BSP XGE 1/4x1/4 BSPT	BSP XGE 1/4x1/4 NPT
250	1/4"	3/8"	BSP XGE 1/4x3/8 BSPT	BSP XGE 1/4x3/8 NPT
	3/8"	1/8"	BSP XGE 3/8x1/8 BSPT	BSP XGE 3/8x1/8 NPT
	3/8"	3/8"	BSP XGE 3/8x3/8 BSPT	BSP XGE 3/8x3/8 NPT
225	3/8"	1/2"	BSP XGE 3/8x1/2 BSPT	BSP XGE 3/8x1/2 NPT
	1/2"	1/4"	BSP XGE 1/2x1/4 BSPT	BSP XGE 1/2x1/4 NPT
200	1/2"	1/2"	BSP XGE 1/2x1/2 BSPT	BSP XGE 1/2x1/2 NPT
	1/2"	3/4"	BSP XGE 1/2x3/4 BSPT	BSP XGE 1/2x3/4 NPT
	3/4"	1/4"	BSP XGE 3/4x1/4 BSPT	BSP XGE 3/4x1/4 NPT
160	3/4"	3/4"	BSP XGE 3/4x3/4 BSPT	BSP XGE 3/4x3/4 NPT
	3/4"	1"	BSP XGE 3/4x1 BSPT	BSP XGE 3/4x1 NPT
	1"	1"	BSP XGE 1x1 BSPT	BSP XGE 1x1 NPT
	1 1/4"	1"	BSP XGE 1 1/4x1 BSPT	BSP XGE 1 1/4x1 NPT
	1 1/4"	1 1/4"	BSP XGE 1 1/4x1 1/4 BSPT	BSP XGE 1 1/4x1 1/4 NPT
100	1 1/2"	1 1/2"	BSP XGE 1 1/2x1 1/2 BSPT	BSP XGE 1 1/2x1 1/2 NPT
	2"	2"	BSP XGE 2x2 BSPT	BSP XGE 2x2 NPT

BSP XGE BSPT / BSP  
BSP XGE NPT / BSP

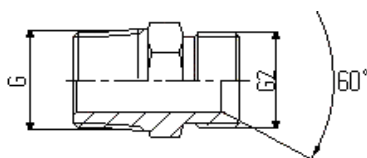

Ciśnienie BAR	Gwint [G]	Gwint [G2]	Oznaczenie <b>BSP XGE BSPT / BSP</b>	Oznaczenie <b>BSP XGE NPT / BSP</b>
350	1/8"	1/8"	BSP XGE 1/8 BSPT / 1/8 BSP	BSP XGE 1/8 NPT / 1/8 BSP
	1/8"	1/4"	BSP XGE 1/8 BSPT / 1/4 BSP	BSP XGE 1/8 NPT / 1/4 BSP
	1/4"	1/8"	BSP XGE 1/4 BSPT / 1/8 BSP	BSP XGE 1/4 NPT / 1/8 BSP
250	1/4"	1/4"	BSP XGE 1/4 BSPT / 1/4 BSP	BSP XGE 1/4 NPT / 1/4 BSP
	1/4"	3/8"	BSP XGE 1/4 BSPT / 3/8 BSP	BSP XGE 1/4 NPT / 3/8 BSP
	3/8"	1/4"	BSP XGE 3/8 BSPT / 1/4 BSP	BSP XGE 3/8 NPT / 1/4 BSP
225	3/8"	3/8"	BSP XGE 3/8 BSPT / 3/8 BSP	BSP XGE 3/8 NPT / 3/8 BSP
	3/8"	1/2"	BSP XGE 3/8 BSPT / 1/2 BSP	BSP XGE 3/8 NPT / 1/2 BSP
	1/2"	3/8"	BSP XGE 1/2 BSPT / 3/8 BSP	BSP XGE 1/2 NPT / 3/8 BSP
200	1/2"	1/2"	BSP XGE 1/2 BSPT / 1/2 BSP	BSP XGE 1/2 NPT / 1/2 BSP
	1/2"	3/4"	BSP XGE 1/2 BSPT / 3/4 BSP	BSP XGE 1/2 NPT / 3/4 BSP
	3/4"	1/2"	BSP XGE 3/4 BSPT / 1/2 BSP	BSP XGE 3/4 NPT / 1/2 BSP
160	3/4"	3/4"	BSP XGE 3/4 BSPT / 3/4 BSP	BSP XGE 3/4 NPT / 3/4 BSP
	3/4"	1"	BSP XGE 3/4 BSPT / 1 BSP	BSP XGE 3/4 NPT / 1 BSP
	1"	3/4"	BSP XGE 1 BSPT / 3/4 BSP	BSP XGE 1 NPT / 3/4 BSP
	1"	1"	BSP XGE 1 BSPT / 1 BSP	BSP XGE 1 NPT / 1 BSP
	1 1/4"	1"	BSP XGE 1 1/4 BSPT / 1 BSP	BSP XGE 1 1/4 NPT / 1 BSP
100	1 1/4"	1 1/4"	BSP XGE 1 1/4 BSPT / 1 1/4 BSP	BSP XGE 1 1/4 NPT / 1 1/4 BSP
	1 1/2"	1 1/4"	BSP XGE 1 1/2 BSPT / 1 1/4 BSP	BSP XGE 1 1/2 NPT / 1 1/4 BSP
	1 1/2"	1 1/2"	BSP XGE 1 1/2 BSPT / 1 1/2 BSP	BSP XGE 1 1/2 NPT / 1 1/2 BSP
	2"	2"	BSP XGE 2 BSPT / 2 BSP	BSP XGE 2 NPT / 2 BSP

BSP GAI

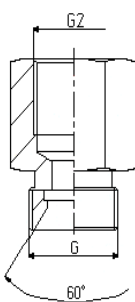

BSP EGE

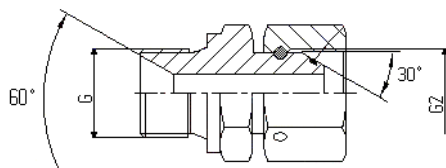

Ciśnienie BAR	Gwint [G]	Gwint [G2]	Oznaczenie <b>BSP GAI</b>	Oznaczenie <b>BSP EGE</b>
350	1/8"	1/8"	BSP GAI 1/8x1/8	BSP EGE 1/8x1/8
	1/4"	1/8"	BSP GAI 1/4x1/8	BSP EGE 1/4x1/8
	1/4"	1/4"	BSP GAI 1/4x1/4	BSP EGE 1/4x1/4
	1/4"	3/8"	BSP GAI 1/4x3/8	BSP EGE 1/4x3/8
	1/4"	1/2"	BSP GAI 1/4x1/2	BSP EGE 1/4x1/2
	3/8"	1/4"	BSP GAI 3/8x1/4	BSP EGE 3/8x1/4
	3/8"	3/8"	BSP GAI 3/8x3/8	BSP EGE 3/8x3/8
	3/8"	1/2"	BSP GAI 3/8x1/2	BSP EGE 3/8x1/2
	3/8"	3/4"	BSP GAI 3/8x3/4	BSP EGE 3/8x3/4
	1/2"	1/4"	BSP GAI 1/2x1/4	BSP EGE 1/2x1/4
	1/2"	3/8"	BSP GAI 1/2x3/8	BSP EGE 1/2x3/8
	1/2"	1/2"	BSP GAI 1/2x1/2	BSP EGE 1/2x1/2
	1/2"	3/4"	BSP GAI 1/2x3/4	BSP EGE 1/2x3/4
	1/2"	1"	BSP GAI 1/2x1	BSP EGE 1/2x1
	315	5/8"	5/8"	BSP GAI 5/8x5/8
3/4"		3/8"	BSP GAI 3/4x3/8	BSP EGE 3/4x3/8
3/4"		1/2"	BSP GAI 3/4x1/2	BSP EGE 3/4x1/2
160	3/4"	3/4"	BSP GAI 3/4x3/4	BSP EGE 3/4x3/4
	3/4"	1"	BSP GAI 3/4x1	BSP EGE 3/4x1
	3/4"	1 1/4"	BSP GAI 3/4x1 1/4	BSP EGE 3/4x1 1/4
	1"	3/8"	BSP GAI 1x3/8	BSP EGE 1x3/8
	1"	1/2"	BSP GAI 1x1/2	BSP EGE 1x1/2
100	1"	3/4"	BSP GAI 1x3/4	BSP EGE 1x3/4
	1"	1"	BSP GAI 1x1	BSP EGE 1x1
	1"	1 1/4"	BSP GAI 1x1 1/4	BSP EGE 1x1 1/4
	1 1/4"	1 1/4"	BSP GAI 1 1/4x1 1/4	BSP EGE 1 1/4x1 1/4
	1 1/2"	1 1/2"	BSP GAI 1 1/2x1 1/2	BSP EGE 1 1/2x1 1/2
	2"	2"	BSP GAI 2x2	BSP EGE 2x2

# ELEMENTY ZŁĄCZNE BSP

BSP XWE BSPT / BSP  
BSP XWE NPT / BSP

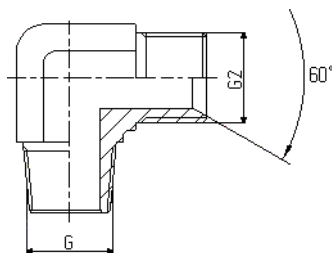

Ciśnienie BAR	Gwint [G]	Gwint [G2]	Oznaczenie	
			<b>BSP XWE BSPT / BSP</b>	<b>BSP XWE NPT / BSP</b>
350	1/8"	1/8"	BSP XWE 1/8 BSPT / 1/8 BSP	BSP XWE 1/8 NPT / 1/8 BSP
	1/8"	1/4"	BSP XWE 1/8 BSPT / 1/4 BSP	BSP XWE 1/8 NPT / 1/4 BSP
	1/4"	1/4"	BSP XWE 1/4 BSPT / 1/4 BSP	BSP XWE 1/4 NPT / 1/4 BSP
250	1/4"	3/8"	BSP XWE 1/4 BSPT / 3/8 BSP	BSP XWE 1/4 NPT / 3/8 BSP
	3/8"	1/4"	BSP XWE 3/8 BSPT / 1/4 BSP	BSP XWE 3/8 NPT / 1/4 BSP
	3/8"	3/8"	BSP XWE 3/8 BSPT / 3/8 BSP	BSP XWE 3/8 NPT / 3/8 BSP
225	3/8"	1/2"	BSP XWE 3/8 BSPT / 1/2 BSP	BSP XWE 3/8 NPT / 1/2 BSP
	1/2"	3/8"	BSP XWE 1/2 BSPT / 3/8 BSP	BSP XWE 1/2 NPT / 3/8 BSP
	1/2"	1/2"	BSP XWE 1/2 BSPT / 1/2 BSP	BSP XWE 1/2 NPT / 1/2 BSP
200	1/2"	5/8"	BSP XWE 1/2 BSPT / 5/8 BSP	BSP XWE 1/2 NPT / 5/8 BSP
	5/8"	5/8"	BSP XWE 5/8 BSPT / 5/8 BSP	BSP XWE 5/8 NPT / 5/8 BSP
	5/8"	3/4"	BSP XWE 5/8 BSPT / 3/4 BSP	BSP XWE 5/8 NPT / 3/4 BSP
	3/4"	5/8"	BSP XWE 3/4 BSPT / 5/8 BSP	BSP XWE 3/4 NPT / 5/8 BSP
	3/4"	3/4"	BSP XWE 3/4 BSPT / 3/4 BSP	BSP XWE 3/4 NPT / 3/4 BSP
160	3/4"	1"	BSP XWE 3/4 BSPT / 1 BSP	BSP XWE 3/4 NPT / 1 BSP
	1"	1"	BSP XWE 1 BSPT / 1 BSP	BSP XWE 1 NPT / 1 BSP
	1"	1 1/4"	BSP XWE 1 BSPT / 1 1/4 BSP	BSP XWE 1 NPT / 1 1/4 BSP
	1 1/4"	1"	BSP XWE 1 1/4 BSPT / 1 BSP	BSP XWE 1 1/4 NPT / 1 BSP
	1 1/4"	1 1/4"	BSP XWE 1 1/4 BSPT / 1 1/4 BSP	BSP XWE 1 1/4 NPT / 1 1/4 BSP
	1 1/4"	1 1/2"	BSP XWE 1 1/4 BSPT / 1 1/2 BSP	BSP XWE 1 1/4 NPT / 1 1/2 BSP
	1 1/2"	1 1/2"	BSP XWE 1 1/2 BSPT / 1 1/2 BSP	BSP XWE 1 1/2 NPT / 1 1/2 BSP
100	2"	2"	BSP XWE 2 BSPT / 2 BSP	BSP XWE 2 NPT / 2 BSP

BSP 45 XWE BSPT / BSP  
BSP 45 XWE NPT / BSP

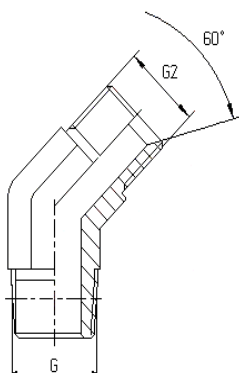

Ciśnienie BAR	Gwint [G]	Gwint [G2]	Oznaczenie	
			<b>BSP 45 XWE BSPT / BSP</b>	<b>BSP 45 XWE NPT / BSP</b>
350	1/8"	1/8"	BSP 45 XWE 1/8 BSPT / 1/8 BSP	BSP 45 XWE 1/8 NPT / 1/8 BSP
	1/8"	1/4"	BSP 45 XWE 1/8 BSPT / 1/4 BSP	BSP 45 XWE 1/8 NPT / 1/4 BSP
	1/4"	1/4"	BSP 45 XWE 1/4 BSPT / 1/4 BSP	BSP 45 XWE 1/4 NPT / 1/4 BSP
250	1/4"	3/8"	BSP 45 XWE 1/4 BSPT / 3/8 BSP	BSP 45 XWE 1/4 NPT / 3/8 BSP
	3/8"	1/4"	BSP 45 XWE 3/8 BSPT / 1/4 BSP	BSP 45 XWE 3/8 NPT / 1/4 BSP
	3/8"	3/8"	BSP 45 XWE 3/8 BSPT / 3/8 BSP	BSP 45 XWE 3/8 NPT / 3/8 BSP
225	3/8"	1/2"	BSP 45 XWE 3/8 BSPT / 1/2 BSP	BSP 45 XWE 3/8 NPT / 1/2 BSP
	1/2"	3/8"	BSP 45 XWE 1/2 BSPT / 3/8 BSP	BSP 45 XWE 1/2 NPT / 3/8 BSP
	1/2"	1/2"	BSP 45 XWE 1/2 BSPT / 1/2 BSP	BSP 45 XWE 1/2 NPT / 1/2 BSP
200	1/2"	5/8"	BSP 45 XWE 1/2 BSPT / 5/8 BSP	BSP 45 XWE 1/2 NPT / 5/8 BSP
	5/8"	5/8"	BSP 45 XWE 5/8 BSPT / 5/8 BSP	BSP 45 XWE 5/8 NPT / 5/8 BSP
	5/8"	3/4"	BSP 45 XWE 5/8 BSPT / 3/4 BSP	BSP 45 XWE 5/8 NPT / 3/4 BSP
	3/4"	5/8"	BSP 45 XWE 3/4 BSPT / 5/8 BSP	BSP 45 XWE 3/4 NPT / 5/8 BSP
	3/4"	3/4"	BSP 45 XWE 3/4 BSPT / 3/4 BSP	BSP 45 XWE 3/4 NPT / 3/4 BSP
160	3/4"	1"	BSP 45 XWE 3/4 BSPT / 1 BSP	BSP 45 XWE 3/4 NPT / 1 BSP
	1"	1"	BSP 45 XWE 1 BSPT / 1 BSP	BSP 45 XWE 1 NPT / 1 BSP
	1"	1 1/4"	BSP 45 XWE 1 BSPT / 1 1/4 BSP	BSP 45 XWE 1 NPT / 1 1/4 BSP
	1 1/4"	1"	BSP 45 XWE 1 1/4 BSPT / 1 BSP	BSP 45 XWE 1 1/4 NPT / 1 BSP
	1 1/4"	1 1/4"	BSP 45 XWE 1 1/4 BSPT / 1 1/4 BSP	BSP 45 XWE 1 1/4 NPT / 1 1/4 BSP
	1 1/4"	1 1/2"	BSP 45 XWE 1 1/4 BSPT / 1 1/2 BSP	BSP 45 XWE 1 1/4 NPT / 1 1/2 BSP
	1 1/2"	1 1/2"	BSP 45 XWE 1 1/2 BSPT / 1 1/2 BSP	BSP 45 XWE 1 1/2 NPT / 1 1/2 BSP
100	2"	2"	BSP 45 XWE 2 BSPT / 2 BSP	BSP 45 XWE 2 NPT / 2 BSP

BSP XWEP

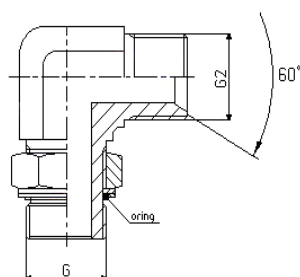

Ciśnienie BAR	Gwint [G]	Gwint [G2]	Oznaczenie	
			<b>BSP XWEP</b>	
350	1/8"	1/8"	BSP XWE 1/8x1/8	
	1/8"	1/4"	BSP XWEP 1/8x1/4	
315	1/4"	1/4"	BSP XWEP 1/4x1/4	
	1/4"	3/8"	BSP XWEP 1/4x3/8	
250	3/8"	3/8"	BSP XWEP 3/8x3/8	
	3/8"	1/2"	BSP XWEP 3/8x1/2	
	1/2"	1/2"	BSP XWEP 1/2x1/2	
	1/2"	3/4"	BSP XWEP 1/2x3/4	
	3/4"	3/4"	BSP XWEP 3/4x3/4	
	3/4"	1"	BSP XWEP 3/4x1	
200	1"	1"	BSP XWEP 1x1	
	1"	1 1/4"	BSP XWEP 1x1 1/4	
	1 1/4"	1 1/4"	BSP XWEP 1 1/4x1 1/4	
160	1 1/4"	1 1/2"	BSP XWEP 1 1/4x1 1/2	
	1 1/2"	1 1/2"	BSP XWEP 1 1/2x1 1/2	
125	1 1/2"	2"	BSP XWEP 1 1/2x2	
	2"	2"	BSP XWEP 2x2	

# ELEMENTY ZŁĄCZNE BSP

BSP 45 XWEP

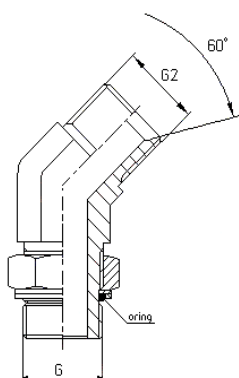

Ciśnienie BAR	Gwint [G]	Gwint [G2]	Oznaczenie <b>BSP 45 XWEP</b>
350	1/8"	1/8"	BSP 45 XWE 1/8x1/8
	1/8"	1/4"	BSP 45 XWEP 1/8x1/4
315	1/4"	1/4"	BSP 45 XWEP 1/4x1/4
	1/4"	3/8"	BSP 45 XWEP 1/4x3/8
250	3/8"	3/8"	BSP 45 XWEP 3/8x3/8
	3/8"	1/2"	BSP 45 XWEP 3/8x1/2
	1/2"	1/2"	BSP 45 XWEP 1/2x1/2
	1/2"	3/4"	BSP 45 XWEP 1/2x3/4
	3/4"	3/4"	BSP 45 XWEP 3/4x3/4
	3/4"	1"	BSP 45 XWEP 3/4x1
200	1"	1"	BSP 45 XWEP 1x1
	1"	1 1/4"	BSP 45 XWEP 1x1 1/4
	1 1/4"	1 1/4"	BSP 45 XWEP 1 1/4x1 1/4
160	1 1/4"	1 1/2"	BSP 45 XWEP 1 1/4x1 1/2
	1 1/2"	1 1/2"	BSP 45 XWEP 1 1/2x1 1/2
125	1 1/2"	2"	BSP 45 XWEP 1 1/2x2
	2"	2"	BSP 45 XWEP 2x2

BSP XWSVP

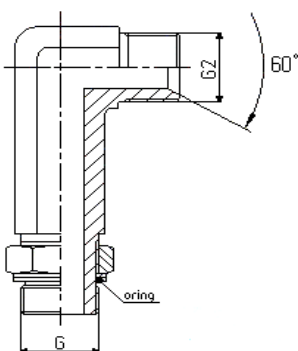

Ciśnienie BAR	Gwint [G]	Gwint [G2]	Oznaczenie <b>BSP XWSVP</b>
350	1/8"	1/8"	BSP XWSVP 1/8x1/8
	1/8"	1/4"	BSP XWSVP 1/8x1/4
315	1/4"	1/4"	BSP XWSVP 1/4x1/4
	1/4"	3/8"	BSP XWSVP 1/4x3/8
250	3/8"	3/8"	BSP XWSVP 3/8x3/8
	3/8"	1/2"	BSP XWSVP 3/8x1/2
	1/2"	1/2"	BSP XWSVP 1/2x1/2
	1/2"	3/4"	BSP XWSVP 1/2x3/4
	3/4"	3/4"	BSP XWSVP 3/4x3/4
	3/4"	1"	BSP XWSVP 3/4x1
200	1"	1"	BSP XWSVP 1x1
	1"	1 1/4"	BSP XWSVP 1x1 1/4
	1 1/4"	1 1/4"	BSP XWSVP 1 1/4x1 1/4
160	1 1/4"	1 1/2"	BSP XWSVP 1 1/4x1 1/2
	1 1/2"	1 1/2"	BSP XWSVP 1 1/2x1 1/2
125	1 1/2"	2"	BSP XWSVP 1 1/2x2
	2"	2"	BSP XWSVP 2x2

BSP XWE GW BSPT / BSP  
BSP XWE GW NPT / BSP

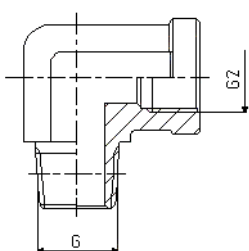

Ciśnienie BAR	Gwint [G]	Gwint [G2]	Oznaczenie <b>BSP XWE GW BSPT / BSP</b>	Oznaczenie <b>BSP XWE GW NPT / BSP</b>
350	1/8"	1/8"	BSP XWE GW 1/8 BSPT / BSP	BSP XWE GW 1/8 NPT / BSP
	1/4"	1/4"	BSP XWE GW 1/4 BSPT / BSP	BSP XWE GW 1/4 NPT / BSP
250	3/8"	3/8"	BSP XWE GW 3/8 BSPT / BSP	BSP XWE GW 3/8 NPT / BSP
225	1/2"	1/2"	BSP XWE GW 1/2 BSPT / BSP	BSP XWE GW 1/2 NPT / BSP
200	3/4"	3/4"	BSP XWE GW 3/4 BSPT / BSP	BSP XWE GW 3/4 NPT / BSP
160	1"	1"	BSP XWE GW 1 BSPT / BSP	BSP XWE GW 1 NPT / BSP
	1 1/4"	1 1/4"	BSP XWE GW 1 1/4 BSPT / BSP	BSP XWE GW 1 1/4 NPT / BSP
	1 1/2"	1 1/2"	BSP XWE GW 1 1/2 BSPT / BSP	BSP XWE GW 1 1/2 NPT / BSP
100	2"	2"	BSP XWE GW 2 BSPT / BSP	BSP XWE GW 2 NPT / BSP

BSP XWE 45 GW BSPT / BSP  
BSP XWE 45 GW NPT / BSP

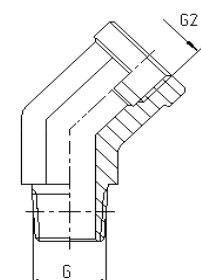

Ciśnienie BAR	Gwint [G]	Gwint [G2]	Oznaczenie <b>BSP XWE 45 GW BSPT / BSP</b>	Oznaczenie <b>BSP XWE 45 GW NPT / BSP</b>
350	1/8"	1/8"	BSP XWE 45 GW 1/8 BSPT / BSP	BSP XWE 45 GW 1/8 NPT / BSP
	1/4"	1/4"	BSP XWE 45 GW 1/4 BSPT / BSP	BSP XWE 45 GW 1/4 NPT / BSP
250	3/8"	3/8"	BSP XWE 45 GW 3/8 BSPT / BSP	BSP XWE 45 GW 3/8 NPT / BSP
225	1/2"	1/2"	BSP XWE 45 GW 1/2 BSPT / BSP	BSP XWE 45 GW 1/2 NPT / BSP
200	3/4"	3/4"	BSP XWE 45 GW 3/4 BSPT / BSP	BSP XWE 45 GW 3/4 NPT / BSP
160	1"	1"	BSP XWE 45 GW 1 BSPT / BSP	BSP XWE 45 GW 1 NPT / BSP
	1 1/4"	1 1/4"	BSP XWE 45 GW 1 1/4 BSPT / BSP	BSP XWE 45 GW 1 1/4 NPT / BSP
	1 1/2"	1 1/2"	BSP XWE 45 GW 1 1/2 BSPT / BSP	BSP XWE 45 GW 1 1/2 NPT / BSP
100	2"	2"	BSP XWE 45 GW 2 BSPT / BSP	BSP XWE 45 GW 2 NPT / BSP

# ELEMENTY ZŁĄCZNE BSP

BSP XEWP BSPT / BSP  
BSP XEWP NPT / BSP

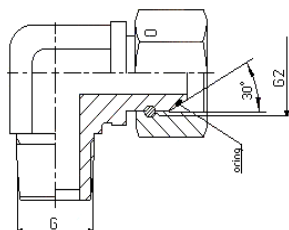

BSP XEWP

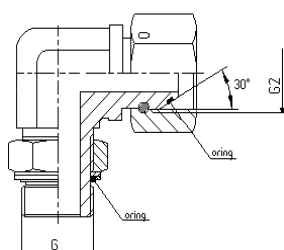

BSP 45 XEWP

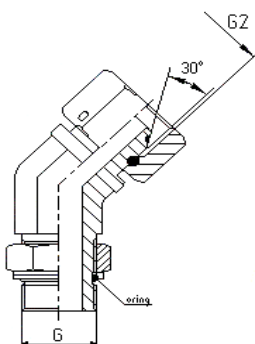

BSP XELE GW BSPT / BSP  
BSP XELE GW NPT / BSP

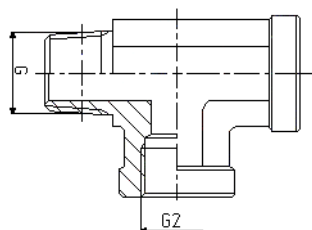

Ciężnienie BAR	Gwint [G]	Gwint [G2]	Oznaczenie	
			<b>BSP XEWP BSPT / BSP</b>	<b>BSP XEWP NPT / BSP</b>
350	1/8"	1/8"	BSP XEWP 1/8 BSPT / BSP	BSP XEWP 1/8 NPT / BSP
	1/4"	1/4"	BSP XEWP 1/4 BSPT / BSP	BSP XEWP 1/4 NPT / BSP
250	3/8"	3/8"	BSP XEWP 3/8 BSPT / BSP	BSP XEWP 3/8 NPT / BSP
225	1/2"	1/2"	BSP XEWP 1/2 BSPT / BSP	BSP XEWP 1/2 NPT / BSP
200	5/8"	1/2"	BSP XEWP 5/8 BSPT / 1/2 BSP	BSP XEWP 5/8 NPT / 1/2 BSP
	3/4"	3/4"	BSP XEWP 3/4 BSPT / BSP	BSP XEWP 3/4 NPT / BSP
160	1"	1"	BSP XEWP 1 BSPT / BSP	BSP XEWP 1 NPT / BSP
	1 1/4"	1 1/4"	BSP XEWP 1 1/4 BSPT / BSP	BSP XEWP 1 1/4 NPT / BSP
	1 1/2"	1 1/2"	BSP XEWP 1 1/2 BSPT / BSP	BSP XEWP 1 1/2 NPT / BSP
100	2"	2"	BSP XEWP 2 BSPT / BSP	BSP XEWP 2 NPT / BSP

Ciężnienie BAR	Gwint [G]	Gwint [G2]	Oznaczenie	
			<b>BSP XEWP</b>	
350	1/8"	1/8"	BSP XEWP 1/8x1/8	
	1/8"	1/4"	BSP XEWP 1/8x1/4	
315	1/4"	1/4"	BSP XEWP 1/4x1/4	
	1/4"	3/8"	BSP XEWP 1/4x3/8	
250	3/8"	3/8"	BSP XEWP 3/8x3/8	
	3/8"	1/2"	BSP XEWP 3/8x1/2	
	1/2"	1/2"	BSP XEWP 1/2x1/2	
	1/2"	3/4"	BSP XEWP 1/2x3/4	
	3/4"	3/4"	BSP XEWP 3/4x3/4	
	3/4"	1"	BSP XEWP 3/4x1	
200	1"	1"	BSP XEWP 1x1	
	1"	1 1/4"	BSP XEWP 1x1 1/4	
	1 1/4"	1 1/4"	BSP XEWP 1 1/4x1 1/4	
160	1 1/4"	1 1/2"	BSP XEWP 1 1/4x1 1/2	
	1 1/2"	1 1/2"	BSP XEWP 1 1/2x1 1/2	
125	1 1/2"	2"	BSP XEWP 1 1/2x2	
	2"	2"	BSP XEWP 2x2	

Ciężnienie BAR	Gwint [G]	Gwint [G2]	Oznaczenie	
			<b>BSP 45 XEWP</b>	
350	1/8"	1/8"	BSP 45 XEWP 1/8x1/8	
	1/8"	1/4"	BSP 45 XEWP 1/8x1/4	
315	1/4"	1/4"	BSP 45 XEWP 1/4x1/4	
	1/4"	3/8"	BSP 45 XEWP 1/4x3/8	
250	3/8"	3/8"	BSP 45 XEWP 3/8x3/8	
	3/8"	1/2"	BSP 45 XEWP 3/8x1/2	
	1/2"	1/2"	BSP 45 XEWP 1/2x1/2	
	1/2"	3/4"	BSP 45 XEWP 1/2x3/4	
	3/4"	3/4"	BSP 45 XEWP 3/4x3/4	
	3/4"	1"	BSP 45 XEWP 3/4x1	
200	1"	1"	BSP 45 XEWP 1x1	
	1"	1 1/4"	BSP 45 XEWP 1x1 1/4	
	1 1/4"	1 1/4"	BSP 45 XEWP 1 1/4x1 1/4	
160	1 1/4"	1 1/2"	BSP 45 XEWP 1 1/4x1 1/2	
	1 1/2"	1 1/2"	BSP 45 XEWP 1 1/2x1 1/2	
125	1 1/2"	2"	BSP 45 XEWP 1 1/2x2	
	2"	2"	BSP 45 XEWP 2x2	

Ciężnienie BAR	Gwint [G]	Gwint [G2]	Oznaczenie	
			<b>BSP XELE BSPT / BSP</b>	<b>BSP XELE NPT / BSP</b>
350	1/8"	1/8"	BSP XELE GW 1/8 BSPT / BSP	BSP XELE GW 1/8 NPT / BSP
	1/4"	1/4"	BSP XELE GW 1/4 BSPT / BSP	BSP XELE GW 1/4 NPT / BSP
250	3/8"	3/8"	BSP XELE GW 3/8 BSPT / BSP	BSP XELE GW 3/8 NPT / BSP
225	1/2"	1/2"	BSP XELE GW 1/2 BSPT / BSP	BSP XELE GW 1/2 NPT / BSP
200	3/4"	3/4"	BSP XELE GW 3/4 BSPT / BSP	BSP XELE GW 3/4 NPT / BSP
160	1"	1"	BSP XELE GW 1 BSPT / BSP	BSP XELE GW 1 NPT / BSP
	1 1/4"	1 1/4"	BSP XELE GW 1 1/4 BSPT / BSP	BSP XELE GW 1 1/4 NPT / BSP
100	1 1/2"	1 1/2"	BSP XELE GW 1 1/2 BSPT / BSP	BSP XELE GW 1 1/2 NPT / BSP
	2"	2"	BSP XELE GW 2 BSPT / BSP	BSP XELE GW 2 NPT / BSP

# ELEMENTY ZŁĄCZNE BSP

BSP XETE GW BSPT / BSP  
BSP XETE GW NPT / BSP

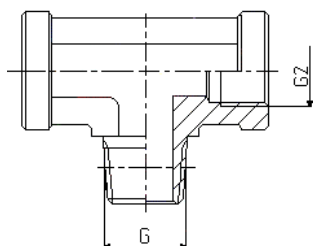

Ciśnienie BAR	Gwint [G]	Gwint [G2]	Oznaczenie BSP XETE BSPT / BSP	Oznaczenie BSP XETE GW NPT / BSP
350	1/8"	1/8"	BSP XETE GW 1/8 BSPT / BSP	BSP XETE GW 1/8 NPT / BSP
	1/4"	1/4"	BSP XETE GW 1/4 BSPT / BSP	BSP XETE GW 1/4 NPT / BSP
250	3/8"	3/8"	BSP XETE GW 3/8 BSPT / BSP	BSP XETE GW 3/8 NPT / BSP
225	1/2"	1/2"	BSP XETE GW 1/2 BSPT / BSP	BSP XETE GW 1/2 NPT / BSP
200	3/4"	3/4"	BSP XETE GW 3/4 BSPT / BSP	BSP XETE GW 3/4 NPT / BSP
160	1"	1"	BSP XETE GW 1 BSPT / BSP	BSP XETE GW 1 NPT / BSP
	1 1/4"	1 1/4"	BSP XETE GW 1 1/4 BSPT / BSP	BSP XETE GW 1 1/4 NPT / BSP
	1 1/2"	1 1/2"	BSP XETE GW 1 1/2 BSPT / BSP	BSP XETE GW 1 1/2 NPT / BSP
100	2"	2"	BSP XETE GW 2 BSPT / BSP	BSP XETE GW 2 NPT / BSP

BSP XTELP

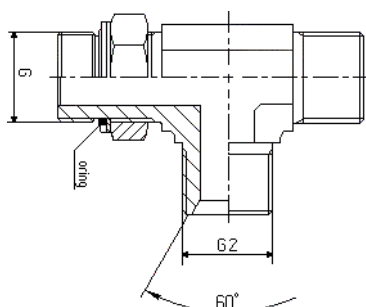

Ciśnienie BAR	Gwint [G]	Gwint [G2]	Oznaczenie BSP XTELP
350	1/8"	1/8"	BSP XTELP 1/8x1/8
	1/8"	1/4"	BSP XTELP 1/8x1/4
315	1/4"	1/4"	BSP XTELP 1/4x1/4
	1/4"	3/8"	BSP XTELP 1/4x3/8
250	3/8"	3/8"	BSP XTELP 3/8x3/8
	3/8"	1/2"	BSP XTELP 3/8x1/2
	1/2"	1/2"	BSP XTELP 1/2x1/2
	1/2"	3/4"	BSP XTELP 1/2x3/4
	3/4"	3/4"	BSP XTELP 3/4x3/4
	3/4"	1"	BSP XTELP 3/4x1
200	1"	1"	BSP XTELP 1x1
	1"	1 1/4"	BSP XTELP 1x1 1/4
	1 1/4"	1 1/4"	BSP XTELP 1 1/4x1 1/4
160	1 1/4"	1 1/2"	BSP XTELP 1 1/4x1 1/2
	1 1/2"	1 1/2"	BSP XTELP 1 1/2x1 1/2
125	1 1/2"	2"	BSP XTELP 1 1/2x2
	2"	2"	BSP XTELP 2x2

BSP XTETP

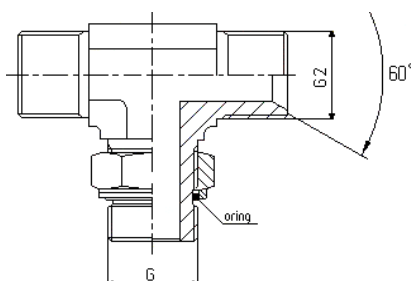

Ciśnienie BAR	Gwint [G]	Gwint [G2]	Oznaczenie BSP XTETP
350	1/8"	1/8"	BSP XTETP 1/8x1/8
	1/8"	1/4"	BSP XTETP 1/8x1/4
315	1/4"	1/4"	BSP XTETP 1/4x1/4
	1/4"	3/8"	BSP XTETP 1/4x3/8
250	3/8"	3/8"	BSP XTETP 3/8x3/8
	3/8"	1/2"	BSP XTETP 3/8x1/2
	1/2"	1/2"	BSP XTETP 1/2x1/2
	1/2"	3/4"	BSP XTETP 1/2x3/4
	3/4"	3/4"	BSP XTETP 3/4x3/4
	3/4"	1"	BSP XTETP 3/4x1
200	1"	1"	BSP XTETP 1x1
	1"	1 1/4"	BSP XTETP 1x1 1/4
	1 1/4"	1 1/4"	BSP XTETP 1 1/4x1 1/4
160	1 1/4"	1 1/2"	BSP XTETP 1 1/4x1 1/2
	1 1/2"	1 1/2"	BSP XTETP 1 1/2x1 1/2
125	1 1/2"	2"	BSP XTETP 1 1/2x2
	2"	2"	BSP XTETP 2x2

BSP XROV

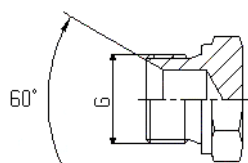

Ciśnienie BAR	Gwint [G]	Oznaczenie BSP XROV
350	1/8"	BSP XROV 1/8
	1/4"	BSP XROV 1/4
	3/8"	BSP XROV 3/8
350	1/2"	BSP XROV 1/2
	5/8"	BSP XROV 5/8
315	3/4"	BSP XROV 3/4
250	1"	BSP XROV 1
200	1 1/4"	BSP XROV 1 1/4
160	1 1/2"	BSP XROV 1 1/2
125	2"	BSP XROV 2

# ELEMENTY ZŁĄCZNE BSP

BSP VKA

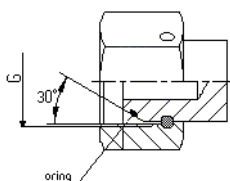

Ciśnienie BAR	Gwint [G]	Oznaczenie BSP VKA
350	1/8"	BSP VKA 1/8
	1/4"	BSP VKA 1/4
	3/8"	BSP VKA 3/8
350	1/2"	BSP VKA 1/2
	5/8"	BSP VKA 5/8
315	3/4"	BSP VKA 3/4
250	1"	BSP VKA 1
200	1 1/4"	BSP VKA 1 1/4
160	1 1/2"	BSP VKA 1 1/2
125	2"	BSP VKA 2

BSP XG

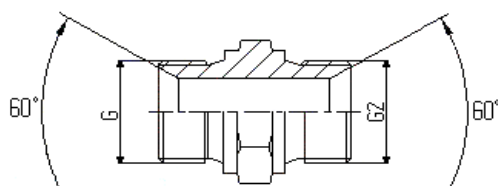

Ciśnienie BAR	Gwint [G]	Gwint [G2]	Oznaczenie BSP XG	Oznaczenie BSP XGR
400	1/8"	1/8"	BSP XG 1/8	
	1/8"	1/4"		BSP XGR 1/8x1/4
	1/8"	3/8"		BSP XGR 1/8x3/8
350	1/8"	1/2"		BSP XGR 1/8x1/2
400	1/4"	1/4"	BSP XG 1/4	
	1/4"	3/8"		BSP XGR 1/4x3/8
350	1/4"	1/2"		BSP XGR 1/4x1/2
	1/4"	5/8"		BSP XGR 1/4x5/8
315	1/4"	3/4"		BSP XGR 1/4x3/4
250	1/4"	1"		BSP XGR 1/4x1
400	3/8"	3/8"	BSP XG 3/8	
	3/8"	1/2"		BSP XGR 3/8x1/2
350	3/8"	5/8"		BSP XGR 3/8x5/8
	3/8"	3/4"		BSP XGR 3/8x3/4
250	3/8"	1"		BSP XGR 3/8x1
350	1/2"	1/2"	BSP XG 1/2	
	1/2"	5/8"		BSP XGR 1/2x5/8
315	1/2"	3/4"		BSP XGR 1/2x3/4
250	1/2"	1"		BSP XGR 1/2x1
200	1/2"	1 1/4"		BSP XGR 1/2x1 1/4
160	1/2"	1 1/2"		BSP XGR 1/2x1 1/2
350	5/8"	5/8"	BSP XG 5/8	
	5/8"	3/4"		BSP XGR 5/8x3/4
250	5/8"	1"		BSP XGR 5/8x1
200	5/8"	1 1/4"		BSP XGR 5/8x1 1/4
315	3/4"	3/4"	BSP XG 3/4	
	3/4"	1"		BSP XGR 3/4x1
200	3/4"	1 1/4"		BSP XGR 3/4x1 1/4
160	3/4"	1 1/2"		BSP XGR 3/4x1 1/2
250	1"	1"	BSP XG 1	
	1"	1 1/4"		BSP XGR 1x1 1/4
125	1"	1 1/2"		BSP XGR 1x1 1/2
100	1"	2"		BSP XGR 1x2
200	1 1/4"	1 1/4"	BSP XG 1 1/4	
160	1 1/4"	1 1/2"		BSP XGR 1 1/4x1 1/2
125	1 1/4"	2"		BSP XGR 1 1/4x2
160	1 1/2"	1 1/2"	BSP XG 1 1/2	
	1 1/2"	2"		BSP XGR 1 1/2x2
125	2"	2"	BSP XG 2"	

BSP XW

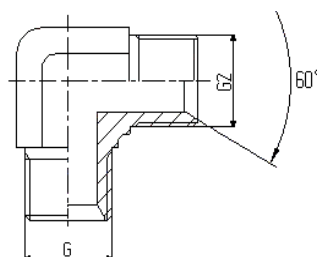

Ciśnienie BAR	Gwint [G]	Gwint [G2]	Oznaczenie BSP XW
400	1/8"	1/8"	BSP XW 1/8
	1/4"	1/4"	BSP XW 1/4
	3/8"	3/8"	BSP XW 3/8
350	1/2"	1/2"	BSP XW 1/2
	5/8"	5/8"	BSP XW 5/8
315	3/4"	3/4"	BSP XW 3/4
250	1"	1"	BSP XW 1
200	1 1/4"	1 1/4"	BSP XW 1 1/4
160	1 1/2"	1 1/2"	BSP XW 1 1/2
125	2"	2"	BSP XW 2

## ELEMENTY ZŁĄCZNE BSP

BSP 45 XW

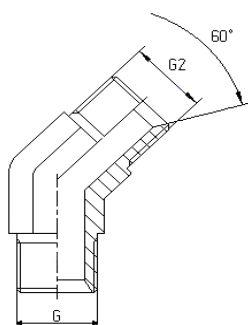

Ciśnienie BAR	Gwint [G]	Gwint [G2]	Oznaczenie <b>BSP XW</b>
400	1/8"	1/8"	BSP XW 1/8
	1/4"	1/4"	BSP XW 1/4
	3/8"	3/8"	BSP XW 3/8
350	1/2"	1/2"	BSP XW 1/2
	5/8"	5/8"	BSP XW 5/8
315	3/4"	3/4"	BSP XW 3/4
250	1"	1"	BSP XW 1
200	1 1/4"	1 1/4"	BSP XW 1 1/4
160	1 1/2"	1 1/2"	BSP XW 1 1/2
125	2"	2"	BSP XW 2

BSP XT

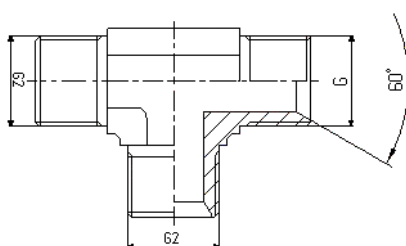

Ciśnienie BAR	Gwint [G]	Gwint [G2]	Oznaczenie <b>BSP XT</b>
400	1/8"	1/8"	BSP XT 1/8
	1/4"	1/4"	BSP XT 1/4
	3/8"	3/8"	BSP XT 3/8
350	1/2"	1/2"	BSP XT 1/2
	5/8"	5/8"	BSP XT 5/8
315	3/4"	3/4"	BSP XT 3/4
250	1"	1"	BSP XT 1
200	1 1/4"	1 1/4"	BSP XT 1 1/4
160	1 1/2"	1 1/2"	BSP XT 1 1/2
125	2"	2"	BSP XT 2

BSP XK

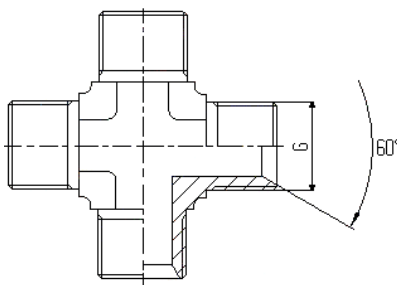

Ciśnienie BAR	Gwint [G]	Gwint [G]	Oznaczenie <b>BSP XK</b>
400	1/8"	1/8"	BSP XK 1/8
	1/4"	1/4"	BSP XK 1/4
	3/8"	3/8"	BSP XK 3/8
350	1/2"	1/2"	BSP XK 1/2
	5/8"	5/8"	BSP XK 5/8
315	3/4"	3/4"	BSP XK 3/4
250	1"	1"	BSP XK 1
200	1 1/4"	1 1/4"	BSP XK 1 1/4
160	1 1/2"	1 1/2"	BSP XK 1 1/2
125	2"	2"	BSP XK 2



# ELEMENTY ZŁĄCZNE BSP

BSP XG GW

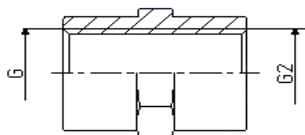

BSP XGR GW

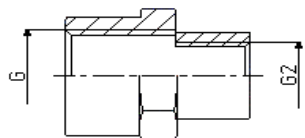

BSP XG GW BSPT / BSP

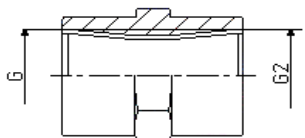

BSP XGR GW BSPT / BSP

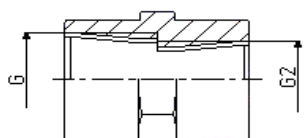

Ciśnienie BAR	Gwint [G]	Gwint [G2]	Oznaczenie BSP XG GW	Oznaczenie BSP XGR
400	1/8"	1/8"	BSP XG GW 1/8	
	1/8"	1/4"		BSP XGR GW 1/8x1/4
	1/8"	3/8"		BSP XGR GW 1/8x3/8
350	1/8"	1/2"		BSP XGR GW 1/8x1/2
	1/4"	1/4"	BSP XG GW 1/4	
400	1/4"	3/8"		BSP XGR GW 1/4x3/8
	1/4"	1/2"		BSP XGR GW 1/4x1/2
350	1/4"	5/8"		BSP XGR GW 1/4x5/8
	315	1/4"	3/4"	BSP XGR GW 1/4x3/4
250	1/4"	1"		BSP XGR GW 1/4x1
400	3/8"	3/8"	BSP XG GW 3/8	
	3/8"	1/2"		BSP XGR GW 3/8x1/2
	3/8"	5/8"		BSP XGR GW 3/8x5/8
315	3/8"	3/4"		BSP XGR GW 3/8x3/4
250	3/8"	1"		BSP XGR GW 3/8x1
350	1/2"	1/2"	BSP XG GW 1/2	
	1/2"	5/8"		BSP XGR GW 1/2x5/8
	315	1/2"	3/4"	BSP XGR GW 1/2x3/4
250	1/2"	1"		BSP XGR GW 1/2x1
200	1/2"	1 1/4"		BSP XGR GW 1/2x1 1/4
350	5/8"	5/8"	BSP XG GW 5/8	
	315	5/8"	3/4"	BSP XGR GW 5/8x3/4
	250	5/8"	1"	BSP XGR GW 5/8x1
200	5/8"	1 1/4"		BSP XGR GW 5/8x1 1/4
315	3/4"	3/4"	BSP XG GW 3/4	
	250	3/4"	1"	BSP XGR GW 3/4x1
	200	3/4"	1 1/4"	BSP XGR GW 3/4x1 1/4
160	3/4"	1 1/2"		BSP XGR GW 3/4x1 1/2
250	1"	1"	BSP XG GW 1	
200	1"	1 1/4"		BSP XGR GW 1x1 1/4
125	1"	1 1/2"		BSP XGR GW 1x1 1/2
100	1"	2"		BSP XGR GW 1x2
200	1 1/4"	1 1/4"	BSP XG GW 1 1/4	
	160	1 1/4"	1 1/2"	BSP XGR GW 1 1/4x1 1/2
	125	1 1/4"	2"	BSP XGR GW 1 1/4x2
160	1 1/2"	1 1/2"	BSP XG GW 1 1/2	
	125	1 1/2"	2"	BSP XGR GW 1 1/2x2
	125	2"	2"	BSP XG GW 2"

Ciśnienie BAR	Gwint [G]	Gwint [G2]	Oznaczenie BSP XG GW BSPT / BSP	Oznaczenie BSP XGR GW BSPT / BSP
400	1/8"	1/8"	BSP XG GW 1/8 BSPT / BSP	
	1/8"	1/4"		BSP XGR GW 1/8 BSPT / 1/4 BSP
	1/8"	3/8"		BSP XGR GW 1/8 BSPT / 3/8 BSP
350	1/8"	1/2"		BSP XGR GW 1/8 BSPT / 1/2 BSP
	1/4"	1/4"	BSP XG GW 1/4 BSPT / BSP	
400	1/4"	3/8"		BSP XGR GW 1/4 BSPT / 3/8 BSP
	1/4"	1/2"		BSP XGR GW 1/4 BSPT / 1/2 BSP
350	1/4"	5/8"		BSP XGR GW 1/4 BSPT / 5/8 BSP
	400	3/8"	3/8"	BSP XG GW 3/8 BSPT / BSP
350	3/8"	1/2"		BSP XGR GW 3/8 BSPT / 1/2 BSP
	3/8"	5/8"		BSP XGR GW 3/8 BSPT / 5/8 BSP
315	3/8"	3/4"		BSP XGR GW 3/8 BSPT / 3/4 BSP
250	3/8"	1"		BSP XGR GW 3/8 BSPT / 1 BSP
350	1/2"	1/2"	BSP XG GW 1/2 BSPT / BSP	
	1/2"	5/8"		BSP XGR GW 1/2 BSPT / 5/8 BSP
	315	1/2"	3/4"	BSP XGR GW 1/2 BSPT / 3/4 BSP
250	1/2"	1"		BSP XGR GW 1/2 BSPT / 1 BSP
200	1/2"	1 1/4"		BSP XGR GW 1/2 BSPT / 1 1/4 BSP
350	5/8"	5/8"	BSP XG GW 5/8 BSPT / BSP	
	315	5/8"	3/4"	BSP XGR GW 5/8 BSPT / 3/4 BSP
	250	5/8"	1"	BSP XGR GW 5/8 BSPT / 1 BSP
200	5/8"	1 1/4"		BSP XGR GW 5/8 BSPT / 1 1/4 BSP
315	3/4"	3/4"	BSP XG GW 3/4 BSPT / BSP	
	250	3/4"	1"	BSP XGR GW 3/4 BSPT / 1 BSP
	200	3/4"	1 1/4"	BSP XGR GW 3/4 BSPT / 1 1/4 BSP
160	3/4"	1 1/2"		BSP XGR GW 3/4 BSPT / 1 1/2 BSP
250	1"	1"	BSP XG GW 1 BSPT / BSP	
200	1"	1 1/4"		BSP XGR GW 1 BSPT / 1 1/4 BSP
125	1"	1 1/2"		BSP XGR GW 1 BSPT / 1 1/2 BSP
100	1"	2"		BSP XGR GW 1 BSPT / 2 BSP
200	1 1/4"	1 1/4"	BSP XG GW 1 1/4 BSPT / BSP	
	160	1 1/4"	1 1/2"	BSP XGR GW 1 1/4 BSPT / 1 1/2 BSP
	125	1 1/4"	2"	BSP XGR GW 1 1/4 BSPT / 2 BSP
160	1 1/2"	1 1/2"	BSP XG GW 1 1/2 BSPT / BSP	
	125	1 1/2"	2"	BSP XGR GW 1 1/2 BSPT / 2 BSP
	125	2"	2"	BSP XG GW 2" BSPT / BSP



# ELEMENTY ZŁĄCZNE BSP

BSP XG GW NPT / BSP

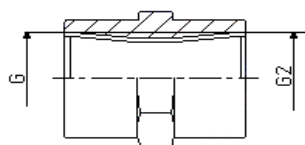

BSP XGR GW NPT / BSP

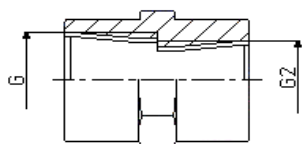

BSP XW GW

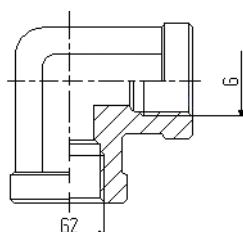

BSP 45 XW GW

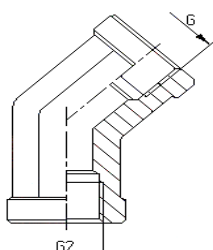

Ciśnienie BAR	Gwint [G]	Gwint [G2]	Oznaczenie <b>BSP XG GW NPT / BSP</b>	Oznaczenie <b>BSP XGR GW NPT / BSP</b>
400	1/8"	1/8"	BSP XG GW 1/8 NPT / BSP	
	1/8"	1/4"		BSP XGR GW 1/8 NPT / 1/4 BSP
	1/8"	3/8"		BSP XGR GW 1/8 NPT / 3/8 BSP
350	1/8"	1/2"		BSP XGR GW 1/8 NPT / 1/2 BSP
400	1/4"	1/4"	BSP XG GW 1/4 NPT / BSP	
	1/4"	3/8"		BSP XGR GW 1/4 NPT / 3/8 BSP
	1/4"	1/2"		BSP XGR GW 1/4 NPT / 1/2 BSP
350	1/4"	5/8"		BSP XGR GW 1/4 PT / 5/8 BSP
400	3/8"	3/8"	BSP XG GW 3/8 NPT / BSP	
350	3/8"	1/2"		BSP XGR GW 3/8 NPT / 1/2 BSP
	3/8"	5/8"		BSP XGR GW 3/8 NPT / 5/8 BSP
	3/8"	3/4"		BSP XGR GW 3/8 NPT / 3/4 BSP
315	3/8"	3/4"		BSP XGR GW 3/8 NPT / 3/4 BSP
250	3/8"	1"		BSP XGR GW 3/8 NPT / 1 BSP
350	1/2"	1/2"	BSP XG GW 1/2 NPT / BSP	
	1/2"	5/8"		BSP XGR GW 1/2 NPT / 5/8 BSP
	1/2"	3/4"		BSP XGR GW 1/2 NPT / 3/4 BSP
315	1/2"	3/4"		BSP XGR GW 1/2 NPT / 3/4 BSP
250	1/2"	1"		BSP XGR GW 1/2 NPT / 1 BSP
200	1/2"	1 1/4"		BSP XGR GW 1/2 NPT / 1 1/4 BSP
350	5/8"	5/8"	BSP XG GW 5/8 NPT / BSP	
315	5/8"	3/4"		BSP XGR GW 5/8 NPT / 3/4 BSP
250	5/8"	1"		BSP XGR GW 5/8 NPT / 1 BSP
200	5/8"	1 1/4"		BSP XGR GW 5/8 BSPT / 1 1/4 BSP
315	3/4"	3/4"	BSP XG GW 3/4 NPT / BSP	
250	3/4"	1"		BSP XGR GW 3/4 NPT / 1 BSP
200	3/4"	1 1/4"		BSP XGR GW 3/4 NPT / 1 1/4 BSP
160	3/4"	1 1/2"		BSP XGR GW 3/4 NPT / 1 1/2 BSP
250	1"	1"	BSP XG GW 1 NPT / BSP	
200	1"	1 1/4"		BSP XGR GW 1 NPT / 1 1/4 BSP
125	1"	1 1/2"		BSP XGR GW 1 NPT / 1 1/2 BSP
100	1"	2"		BSP XGR GW 1 NPT / 2 BSP
200	1 1/4"	1 1/4"	BSP XG GW 1 1/4 NPT / BSP	
160	1 1/4"	1 1/2"		BSP XGR GW 1 1/4 NPT / 1 1/2 BSP
125	1 1/4"	2"		BSP XGR GW 1 1/4 NPT / 2 BSP
160	1 1/2"	1 1/2"	BSP XG GW 1 1/2 NPT / BSP	
125	1 1/2"	2"		BSP XGR GW 1 1/2 NPT / 2 BSP
	2"	2"	BSP XG GW 2" NPT / BSP	

Ciśnienie BAR	Gwint [G]	Gwint [G2]	Oznaczenie <b>BSP XW GW</b>
350	1/8"	1/8"	BSP XW GW 1/8
	1/4"	1/4"	BSP XW GW 1/4
250	3/8"	3/8"	BSP XW GW 3/8
225	1/2"	1/2"	BSP XW GW 1/2
200	3/4"	3/4"	BSP XW GW 3/4
160	1"	1"	BSP XW GW 1
	1 1/4"	1 1/4"	BSP XW GW 1 1/4
	1 1/2"	1 1/2"	BSP XW GW 1 1/2
100	2"	2"	BSP XW GW 2

Ciśnienie BAR	Gwint [G]	Gwint [G2]	Oznaczenie <b>BSP 45 XW GW</b>
350	1/8"	1/8"	BSP 45 XW GW 1/8
	1/4"	1/4"	BSP 45 XW GW 1/4
250	3/8"	3/8"	BSP 45 XW GW 3/8
225	1/2"	1/2"	BSP 45 XW GW 1/2
200	3/4"	3/4"	BSP 45 XW GW 3/4
160	1"	1"	BSP 45 XW GW 1
	1 1/4"	1 1/4"	BSP 45 XW GW 1 1/4
	1 1/2"	1 1/2"	BSP 45 XW GW 1 1/2
100	2"	2"	BSP 45 XW GW 2

# ELEMENTY ZŁĄCZNE BSP

BSP XT GW  
BSP XT GW NPT

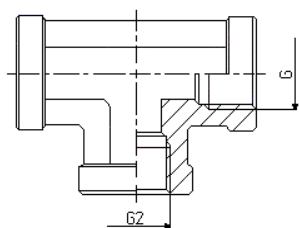

Ciśnienie BAR	Gwint [G]	Gwint [G2]	Oznaczenie <b>BSP XT GW</b>	Oznaczenie <b>BSP XT GW NPT</b>
350	1/8"	1/8"	BSP XT GW 1/8	BSP XT GW 1/8 NPT
	1/4"	1/4"	BSP XT GW 1/4	BSP XT GW 1/4 NPT
250	3/8"	3/8"	BSP XT GW 3/8	BSP XT GW 3/8 NPT
225	1/2"	1/2"	BSP XT GW 1/2	BSP XT GW 1/2 NPT
200	3/4"	3/4"	BSP XT GW 3/4	BSP XT GW 3/4 NPT
160	1"	1"	BSP XT GW 1	BSP XT GW 1 NPT
	1 1/4"	1 1/4"	BSP XT GW 1 1/4	BSP XT GW 1 1/4 NPT
	1 1/2"	1 1/2"	BSP XT GW 1 1/2	BSP XT GW 1 1/2 NPT
100	2"	2"	BSP XT GW 2	BSP XT GW 2 NPT

BSP XK GW  
BSP XK GW NPT

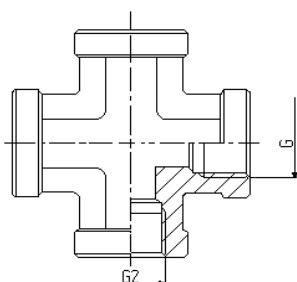

Ciśnienie BAR	Gwint [G]	Gwint [G]	Oznaczenie <b>BSP XK GW</b>	Oznaczenie <b>BSP XK GW NPT</b>
350	1/8"	1/8"	BSP XK GW 1/8	BSP XK GW 1/8 NPT
	1/4"	1/4"	BSP XK GW 1/4	BSP XK GW 1/4 NPT
250	3/8"	3/8"	BSP XK GW 3/8	BSP XK GW 3/8 NPT
225	1/2"	1/2"	BSP XK GW 1/2	BSP XK GW 1/2 NPT
200	3/4"	3/4"	BSP XK GW 3/4	BSP XK GW 3/4 NPT
160	1"	1"	BSP XK GW 1	BSP XK GW 1 NPT
	1 1/4"	1 1/4"	BSP XK GW 1 1/4	BSP XK GW 1 1/4 NPT
	1 1/2"	1 1/2"	BSP XK GW 1 1/2	BSP XK GW 1 1/2 NPT
100	2"	2"	BSP XK GW 2	BSP XK GW 2 NPT

BSP GZ

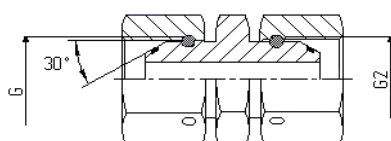

Ciśnienie BAR	Gwint [G]	Gwint [G2]	Oznaczenie <b>BSP GZ</b>	Oznaczenie <b>BSP GZR</b>
400	1/8"	1/8"	BSP GZ 1/8	
	1/8"	1/4"		BSP GZR 1/8x1/4
	1/8"	3/8"		BSP GZR 1/8x3/8
400	1/4"	1/4"	BSP GZ 1/4	
	1/4"	3/8"		BSP GZR 1/4x3/8
350	1/4"	1/2"		BSP GZR 1/4x1/2
400	3/8"	3/8"	BSP GZ 3/8	
	3/8"	1/2"		BSP GZR 3/8x1/2
350	3/8"	5/8"		BSP GZR 3/8x5/8
	1/2"	1/2"	BSP GZ 1/2	
350	1/2"	5/8"		BSP GZR 1/2x5/8
	1/2"	3/4"		BSP GZR 1/2x3/4
315	5/8"	5/8"	BSP GZ 5/8	
315	5/8"	3/4"		BSP GZR 5/8x3/4
250	5/8"	1"		BSP GZR 5/8x1
315	3/4"	3/4"	BSP GZ 3/4	
250	3/4"	1"		BSP GZR 3/4x1
250	1"	1"	BSP GZ 1	
200	1"	1 1/4"		BSP GZR 1x1 1/4
125	1"	1 1/2"		BSP GZR 1x1 1/2
200	1 1/4"	1 1/4"	BSP GZ 1 1/4	
160	1 1/4"	1 1/2"		BSP GZR 1 1/4x1 1/2
125	1 1/4"	2"		BSP GZR 1 1/4x2
160	1 1/2"	1 1/2"	BSP GZ 1 1/2	
	1 1/2"	2"		BSP GZR 1 1/2x2
125	2"	2"	BSP GZ 2"	

# ELEMENTY ZŁĄCZNE BSP

BSP XEW

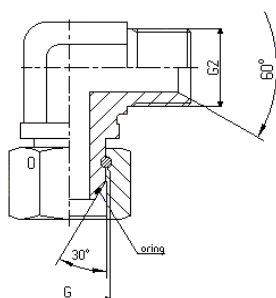

Ciśnienie BAR	Gwint [G]	Gwint [G2]	Oznaczenie <b>BSP XEW</b>
400	1/8"	1/8"	BSP XEW 1/8
	1/4"	1/4"	BSP XEW 1/4
	3/8"	3/8"	BSP XEW 3/8
350	1/2"	1/2"	BSP XEW 1/2
	5/8"	5/8"	BSP XEW 5/8
315	3/4"	3/4"	BSP XEW 3/4
250	1"	1"	BSP XEW 1
200	1 1/4"	1 1/4"	BSP XEW 1 1/4
160	1 1/2"	1 1/2"	BSP XEW 1 1/2
125	2"	2"	BSP XEW 2

BSP 45 XEW

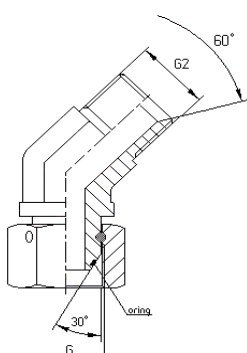

Ciśnienie BAR	Gwint [G]	Gwint [G2]	Oznaczenie <b>BSP 45 XEW</b>
400	1/8"	1/8"	BSP 45 XEW 1/8
	1/4"	1/4"	BSP 45 XEW 1/4
	3/8"	3/8"	BSP 45 XEW 3/8
350	1/2"	1/2"	BSP 45 XEW 1/2
	5/8"	5/8"	BSP 45 XEW 5/8
315	3/4"	3/4"	BSP 45 XEW 3/4
250	1"	1"	BSP 45 XEW 1
200	1 1/4"	1 1/4"	BSP 45 XEW 1 1/4
160	1 1/2"	1 1/2"	BSP 45 XEW 1 1/2
125	2"	2"	BSP 45 XEW 2

BSP XEL

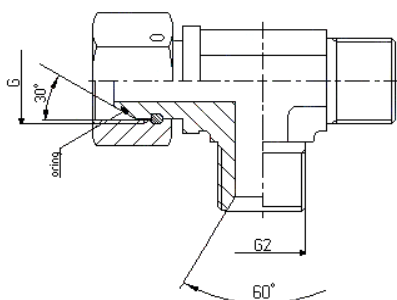

Ciśnienie BAR	Gwint [G]	Gwint [G2]	Oznaczenie <b>BSP XEL</b>
400	1/8"	1/8"	BSP XEL 1/8
	1/4"	1/4"	BSP XEL 1/4
	3/8"	3/8"	BSP XEL 3/8
350	1/2"	1/2"	BSP XEL 1/2
	5/8"	5/8"	BSP XEL 5/8
315	3/4"	3/4"	BSP XEL 3/4
250	1"	1"	BSP XEL 1
200	1 1/4"	1 1/4"	BSP XEL 1 1/4
160	1 1/2"	1 1/2"	BSP XEL 1 1/2
125	2"	2"	BSP XEL 2

BSP XET

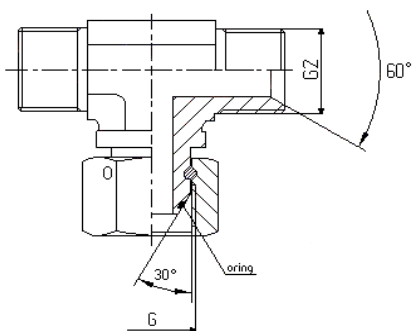

Ciśnienie BAR	Gwint [G]	Gwint [G2]	Oznaczenie <b>BSP XET</b>
400	1/8"	1/8"	BSP XET 1/8
	1/4"	1/4"	BSP XET 1/4
	3/8"	3/8"	BSP XET 3/8
350	1/2"	1/2"	BSP XET 1/2
	5/8"	5/8"	BSP XET 5/8
315	3/4"	3/4"	BSP XET 3/4
250	1"	1"	BSP XET 1
200	1 1/4"	1 1/4"	BSP XET 1 1/4
160	1 1/2"	1 1/2"	BSP XET 1 1/2
125	2"	2"	BSP XET 2

# ELEMENTY ZŁĄCZNE BSP

BSP 2G XW

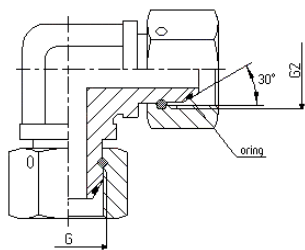

Ciśnienie BAR	Gwint [G]	Gwint [G2]	Oznaczenie <b>BSP 2G XW</b>
400	1/8"	1/8"	BSP 2G XW 1/8
	1/4"	1/4"	BSP 2G XW 1/4
	3/8"	3/8"	BSP 2G XW 3/8
350	1/2"	1/2"	BSP 2G XW 1/2
	5/8"	5/8"	BSP 2G XW 5/8
315	3/4"	3/4"	BSP 2G XW 3/4
250	1"	1"	BSP 2G XW 1
200	1 1/4"	1 1/4"	BSP 2G XW 1 1/4
160	1 1/2"	1 1/2"	BSP 2G XW 1 1/2
125	2"	2"	BSP 2G XW 2

BSP 3G XT

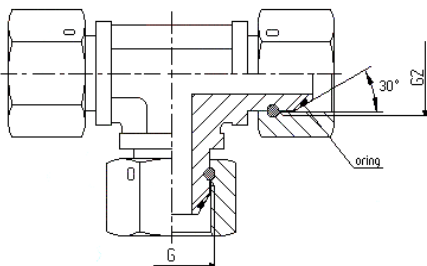

Ciśnienie BAR	Gwint [G]	Gwint [G]	Oznaczenie <b>BSP 3G XT</b>
400	1/8"	1/8"	BSP 3G XT 1/8
	1/4"	1/4"	BSP 3G XT 1/4
	3/8"	3/8"	BSP 3G XT 3/8
350	1/2"	1/2"	BSP 3G XT 1/2
	5/8"	5/8"	BSP 3G XT 5/8
315	3/4"	3/4"	BSP 3G XT 3/4
250	1"	1"	BSP 3G XT 1
200	1 1/4"	1 1/4"	BSP 3G XT 1 1/4
160	1 1/2"	1 1/2"	BSP 3G XT 1 1/2
125	2"	2"	BSP 3G XT 2